

# Basic Chord Families

CHORD NAME	FORMULA
------------	---------

## Major Chord Family - I, IV

Major	1 3 5
Major 7	1 3 5 7
Major 6	1 3 5 6
Major 9	1 3 5 7 9
Major 6/9	1 3 5 6 9
Major 7+11	1 3 5 7 - +11
Major 6+11	1 3 5 6 - +11
Major 9+11	1 3 5 7 9 +11
Major 6/9+11	1 3 5 6 9 +11
Major 13+11	1 3 5 7 9 +11 13

## Minor Chord Family - II, III, VI

Minor	1 b3 5
Minor 7	1 b3 5 b7
Minor 6	1 b3 5 6
Minor 9	1 b3 5 b7 9
Minor 6/9	1 b3 5 6 9
Minor 7(add 11)	1 b3 5 b7 - 11
Minor 6(add 11)	1 b3 5 6 - 11
Minor 11	1 b3 5 b7 9 11
Minor 6/9(add 11)	1 b3 5 6 9 11
Minor 13	1 b3 5 b7 9 11 13

## Dominant Chord Family - V7

Major	1 3 5
7	1 3 5 b7
6	1 3 5 6
9	1 3 5 b7 9
6/9	1 3 5 6 9
11	1 3 5 b7 9 11
6(add 11)	1 3 5 6 - 11
6/9(add 11)	1 3 5 6 9 11
13	1 3 5 b7 9 11 13

## Alterations (Tensions)

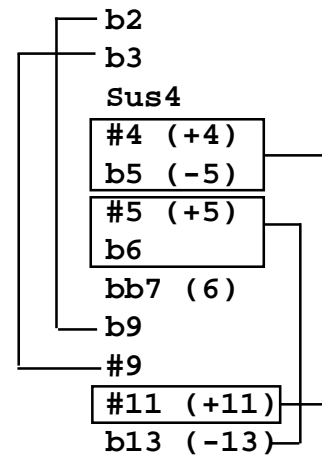

## Common Altered Chords

Majb5	1 3 b5
Maj7b5	1 3 b5 7
Mi7b5	1 b3 b5 b7
Dim7	1 b3 b5 bb7
Aug	1 3 #5
Aug7	1 3 #5 b7
7b9	1 3 5 b7 b9
7#9	1 3 5 b7 #9
Mi9b5	1 b3 b5 b7 9
7b5	1 3 b5 b7
9+11	1 3 5 b7 9 +11